

SPECIFICATIONS

EXCEPT AS MODIFIED BY THESE PLANS AND THE DETAIL SPECIFICATIONS PERTAINING THERETO, ALL WORK ON THIS PROJECT SHALL BE GOVERNED (IN ORDER) BY THE REQUIREMENTS OF THE CITY OF SYLVANIA, LUCAS COUNTY ENGINEER AND BY THE CURRENT STATE OF OHIO DEPARTMENT OF TRANSPORTATION, CONSTRUCTION AND MATERIAL SPECIFICATION AND ANY SUPPLEMENTAL STATE SPECIFICATIONS AS MAY BE IN EFFECT FOURTEEN (14) CALENDAR DAYS PRIOR TO THE AWARD OF THIS CONTRACT. IN THE AFORESAID STATE SPECIFICATIONS, THE WORDS "STATE", "DIRECTOR", AND "ENGINEER" SHALL BE HELD TO MEAN THE CITY OF SYLVANIA, OR ITS DULY APPOINTED REPRESENTATIVE.

THE SPECIFICATIONS OF THE AMERICAN NATIONAL STANDARDS INSTITUTE (ANSI), AMERICAN WATER WORKS ASSOCIATION (AWWA) AND THE AMERICAN SOCIETY OF TESTING AND MATERIALS (ASTM) HEREIN REFERRED TO, UNLESS OTHERWISE NOTED, SHALL BE THE LATEST SPECIFICATIONS OF THE RESPECTIVE ORGANIZATIONS.

ALL MATERIAL SHALL BE MANUFACTURED IN THE UNITED STATES OF AMERICA. COPIES OF SUPPLIERS INVOICES SHALL BE SUBMITTED TO THE CITY OF SYLVANIA.

SEWER-WATERLINE SEPARATION

WATERLINE INSTALLATIONS SHALL BE LAID WITH AT LEAST TEN (10) FEET HORIZONTAL AND EIGHTEEN (18) INCHES VERTICAL SEPARATION FROM ANY SANITARY SEWER MEASURED EDGE TO EDGE.

MISCELLANEOUS

IN SOME INSTALLATIONS (NEAR BENDS OR DEAD ENDS), THE CITY MAY REQUIRE THE USE OF FRICTION CLAMPS, RESTRAINING GASKETS OR TIE RODS TO ANCHOR THE SECTIONS OF PIPE.

CROSSING OF EXISTING PIPES AND UTILITIES

WHERE THE PLANS PROVIDE FOR A PROPOSED WATERLINE TO CROSS OVER OR UNDER AN EXISTING CONDUIT OR FACILITY, THE CONTRACTOR SHALL LOCATE THE EXISTING CONDUIT OR FACILITY BOTH AS TO LINE AND GRADE BEFORE STARTING TO LAY ANY PORTION OF THE PROPOSED WATERLINE WHICH COULD BE AFFECTED BY THE LOCATION OF THE EXISTING CONDUIT OR FACILITY.

IF THE CONTRACTOR DETERMINES THAT THE ELEVATION OF AN EXISTING CONDUIT DIFFERS FROM THE PLAN ELEVATION OR NECESSITATES A CHANGE IN THE PROPOSED INSTALLATION, THE CITY SHALL BE NOTIFIED BEFORE STARTING CONSTRUCTION OF ANY PORTION OF THE PROPOSED WATERLINE WHICH WILL BE AFFECTED BY THE VARIANCE IN THE EXISTING ELEVATION.

IF THE CONTRACTOR DETERMINES THAT THE PROPOSED WATERLINE WILL INTERSECT AN EXISTING CONDUIT OR FACILITY IF CONSTRUCTED AS SHOWN ON THE PLANS, THE ENGINEER SHALL BE NOTIFIED BEFORE STARTING CONSTRUCTION OR ANY PORTION OF THE PROPOSED WATERLINE WHICH WOULD BE AFFECTED BY THE INTERFERENCE WITH AN EXISTING CONDUIT OR FACILITY.

THE CONTRACTOR SHALL BE RESPONSIBLE FOR ADDITIONAL COSTS RESULTING FROM FAILURE TO COMPLY WITH THIS NOTE.

PAYMENT FOR ALL THE OPERATIONS DESCRIBED ABOVE SHALL BE INCLUDED IN THE CONTRACT PRICE FOR THE PERTINENT 638 WATERLINE ITEM.

WATER SUPPLY PIPE

ALL WATER MAINS SHALL BE DUCTILE IRON PIPE, CENTRIFUGALLY CAST, OR, POLYVINYL CHLORIDE PLASTIC PIPE.

DUCTILE IRON PIPE SHALL CONFORM TO ANSI-A21.51 (AWWA C-151). MINIMUM WALL THICKNESS SHALL MEET THE REQUIREMENTS OF ANSI-A21.51, TABLE 51.4, CLASS 54 (6" OR 8" DIAMETER), CLASS 53 (12" DIAMETER) OR CLASS 52 (16" DIAMETER).

PIPE BENDS AND FITTINGS SHALL BE CEMENT LINED CONFORMING TO ANSI-A21.4 (AWWA C-104). THE OUTSIDE COATING SHALL BE A MINIMUM 1/32 INCH COAL TAR ENAMEL. IF COATING IS DISTURBED, IT SHALL BE REPLACED. ALL BOLTS, NUTS, ETC. USED SHALL BE COR-BLUE STEEL, STAINLESS STEEL OR EQUAL AND SHALL BE COATED AFTER INSTALLATION USING AN APPROVED ASPHALTIC BASE MATERIAL.

DUCTILE IRON FITTINGS AND SPECIALS SHALL CONFORM TO ANSI-A21.10 (AWWA C-110) OR ANSI-A21.53 (AWWA C-153) WITH A MINIMUM CLASS OF 250. FITTINGS SHALL HAVE MECHANICAL JOINTS MEETING ANSI-A21.11 (AWWA C-111).

RUBBER GASKETS SHALL BE USED ON ALL MECHANICAL JOINT FITTINGS AND SHALL CONFORM TO ANSI-A21.11 (AWWA C-111). LEAD TIPPED RUBBER GASKETS SHALL NOT BE PERMITTED. BRONZE WEDGES SHALL BE USED AT ALL PUSH-ON JOINTS (FOUR PER JOINT).

PVC PIPE FOR SIZES 4" THROUGH 12" DIAMETER SHALL BE A MINIMUM OF DR18 WITH DUCTILE IRON EQUIVALENT OUTSIDE DIAMETER IN ACCORDANCE WITH AWWA C900. PIPE SHALL BE OF THE INTEGRAL WALL-THICKENED BELL END TYPE INCORPORATING ELASTOMERIC GASKETS TO AFFECT THE PRESSURE SEAL AND DESIGNED FOR DIRECT CONNECTION INTO DUCTILE IRON FITTINGS USING MECHANICAL JOINTS.

DETECTABLE LOCATING TRACER WIRE (COPPERHEAD SNAKEBIT DRYCONN DIRECT BURY 3-WAY LUG OR APPROVED EQUAL) SHALL BE INSTALLED DIRECTLY OVER AND ON THE CENTER OF NON-METALLIC PRESSURE PIPE AND SERVICES ALONG THE ENTIRE LENGTH. THE TRACER WIRE SHALL BE BROUGHT TO THE SURFACE IN A COPPERHEAD INDUSTRIES SNAKBIT ROADWAY TRACER BOX ON THE OUTSIDE OF ALL VALVE BOXES, FIRE HYDRANTS, AND CURB BOXES. INTERVALS SHALL NOT EXCEED 500 FEET. 4-FOOT EXTRA TRACER WIRE EXTENSION SHALL BE PROVIDED AT EACH ACCESS POINT. TRACER SHALL BE TESTED FOR CONTINUITY AFTER INSTALLATION.

MECHANICAL JOINT RESTRAINT

PIPE SHALL BE ANCHORED AT DEAD ENDS, BENDS, TEES, VALVES AND OTHER FITTINGS REQUIRING RESTRAINT BY MEANS OF MECHANICAL JOINT RESTRAINT. MECHANICAL JOINT RESTRAINT SHALL BE INCORPORATED IN THE DESIGN OF THE FOLLOWER GLAND AND SHALL INCLUDE A RESTRAINING MECHANISM WHICH, WHEN ACTUATED, IMPARTS MULTIPLE WEDGING ACTION AGAINST THE PIPE, INCREASING ITS RESISTANCE AS THE PRESSURE INCREASES. FLEXIBILITY OF THE JOINT SHALL BE MAINTAINED AFTER BURIAL. GLANDS SHALL BE MANUFACTURED OF DUCTILE IRON CONFORMING TO ASTM A 538-80. RESTRAINING DEVICES SHALL BE OF DUCTILE IRON HEAT TREATED TO A MINIMUM HARDNESS OF 370 BHN. DIMENSIONS OF THE GLAND SHALL BE SUCH THAT IT CAN BE USED WITH THE STANDARDIZED MECHANICAL JOINT BELL AND TEE-HEAD BOLTS CONFORMING TO ANSI/AWWA A21.11 AND ANSI/AWWA C153/A21.53 OF LATEST REVISION. TWIST-OFF NUTS SHALL BE USED TO INSURE PROPER ACTUATING OF THE RESTRAINING DEVICES. THE MECHANICAL JOINT RESTRAINT DEVICE SHALL HAVE A WORKING PRESSURE OF AT LEAST 250 PSI WITH A MINIMUM SAFETY FACTOR OF 2:1.

WATERLINE LENGTHS

ALL LENGTHS SHOWN ON PLAN VIEWS ARE MEASURED FROM CENTERLINE OF VALVE OR FITTINGS IF APPLICABLE. ALL DEAD END WATER MAINS SHALL END WITH AN APPROVED BLOW OFF ASSEMBLY.

CASTINGS ADJUSTED TO GRADE

ALL MANHOLE AND VALVE BOX CASTINGS LOCATED WITHIN PAVED AREAS SHALL BE ADJUSTED TO FINAL GRADE USING A "MR. MANHOLE" SYSTEM OR AN APPROVED EQUAL METHOD, ENSURING A CIRCULAR CUT-OUT OF THE SURROUNDING PAVEMENT FOR A PRECISE FIT. FOLLOWING THE ADJUSTMENT OF THE CASTING TO THE FINISHED PAVEMENT GRADE AND SLOPE, A CONCRETE COLLAR SHALL BE INSTALLED USING HIGH-EARLY-STRENGTH CONCRETE (CLASS MS OR AS SPECIFIED) TO FACILITATE TIMELY REOPENING TO TRAFFIC. THE CONCRETE COLLAR SHALL BE FINISHED 1/4" BELOW THE FINISHED ADJACENT ASPHALT SURFACE. ALL JOINTS BETWEEN THE CONCRETE COLLAR AND THE EXISTING PAVEMENT SHALL BE THOROUGHLY CLEANED AND SEALED WITH A HOT-APPLIED JOINT SEALANT.

UNLESS OTHERWISE SPECIFIED, PAYMENT FOR ALL OPERATIONS DESCRIBED SHALL BE INCLUDED IN THE UNIT PRICES BID FOR "ADJUSTED TO GRADE" LINE ITEMS FOR THE PERTINENT ITEM (I.E. MANHOLE, VALVE BOX, ETC.).

VALVE BOXES

MAIN LINE AND HYDRANT BRANCH VALVES ARE TO BE ENCLOSED IN A STANDARD VALVE BOX. VALVE BOXES SHALL BE OF THE BUFFALO THREE PIECE SCREW TYPE, WITH A 5 1/4 INCH SHAFT; LIMITED TO THE FOLLOWING:

BUFFALO PIPE & FOUNDRY COMPANY
CLOW CORPORATION

GATE VALVES

316 STAINLESS STEEL OR EQUAL NUTS & BOLTS SHALL BE FURNISHED ON ALL GATE VALVES.

GATE VALVES SHALL BE CAST IRON BODIED OR RESILIENT-SEAT, CORROSION-RESISTANT, 200 POUND WORKING PRESSURE, NON-RISING STEM TYPE INTENDED FOR USE IN VERTICAL SETTINGS. ALL FASTENERS, BOLTS AND NUTS USED ON STUFFING BOX AND BONNET CAP SHALL BE STAINLESS STEEL. VALVES, 12" OR SMALLER, SHALL BE LIMITED TO VALVES MADE BY MUELLER, KENNEDY, OR AMERICAN VALVE COMPANIES AWWA C-500 OR AWWA C-509 (RESILIENT SEAT) AS APPROVED BY THE CITY OF SYLVANIA.

VALVES ARE TO OPEN BY TURNING LEFT, OR COUNTERCLOCKWISE, AND SHALL BE FURNISHED WITH A 2 INCH SQUARE OPERATING NUT WITH THE DIRECTION INDICATED BY A CLEARLY VISIBLE ARROW CAST INTO THE VALVE.

TAPPING SLEEVES

IF USED, TAPPING SLEEVES MUST BE CONSTRUCTED OF 304 STAINLESS STEEL INCLUDING BOLTS AND NUTS. BOLTS MUST BE CONNECTED TO THE SLEEVE. SLEEVE MUST BE EQUIPPED WITH HEAVY GAUGE ARMORS. THE FLANGE GASKET MUST BE GLUED TO THE FLANGE FACE.

FIRE HYDRANTS

HYDRANTS SHALL BE OF THE 5 1/4 INCH VALVE OPENING COMPRESSION TYPE, OPENING AGAINST AND CLOSING WITH THE WATER PRESSURE, OPENING BY TURNING THE OPERATING NUT TO THE LEFT, COUNTERCLOCKWISE DIRECTION. HYDRANTS TO BE USED IN THE CITY OF SYLVANIA DISTRIBUTION SYSTEM SHALL BE LIMITED TO THE FOLLOWING (MEETING AWWA C-502):

AMERICAN-DARLING MODEL B-62-B
KENNEDY GUARDIAN K-81A
MUELLER SUPER CENTURION 250

ALL REQUIRED THREAD SIZES SHALL BE OF THE SAME SIZE AND TYPE USED IN LUCAS COUNTY AND THE CITY OF TOLEDO SYSTEM.

HYDRANT REPLACEMENT PARTS, INCLUDING EXTENSIONS, CAPS, NOZZLES AND ALL EXTERNAL AND INTERNAL PARTS SHALL BE OF SAME MANUFACTURER AS HYDRANT. CONTRACTOR SHALL SUPPLY COPIES OF INVOICES OF REPLACEMENT PARTS.

CAPS SHALL HAVE GASKETS AND BE SECURED TO THE HYDRANT BY HOT-DIPPED, WELDED, GALVANIZED CHAINS OF 3/16" DIAMETER.

PUMPER NOZZLE SHALL BE 4 1/2 INCHES INTERNAL DIAMETER WITH STORZ CONNECTOR FROM HARRINGTON, INC. OR MUELLER, INC. STORZ CONNECTOR SHALL BE AN INTEGRAL PART OF THE HYDRANT ASSEMBLY. HYDRANTS ARE LIMITED TO THOSE PROVIDED WITH THE INTEGRAL STORZ CONNECTOR. THE STORZ CAP SHALL BE CONNECTED TO THE HYDRANT WITH A 0.125" VINYL COATED AIRCRAFT CABLE. THE ENTIRE STORZ CONNECTOR SHALL BE IN ACCORDANCE WITH THE SPECIFICATIONS OF HARRINGTON, INC. OR MUELLER, INC. THE 2 1/2" NOZZLES SHALL BE LUCAS COUNTY / CITY OF TOLEDO THREADS. NUTS AND BOLTS EXPOSED TO SOIL SHALL BE 316 STAINLESS STEEL. STORZ CONNECTOR AND CAP ARE NOT TO BE PAINTED.

ALL APPLICABLE CONNECTIONS AND FITTINGS IN THE HYDRANT DETAILS SHALL BE INCLUDED WITH THE CONTRACT UNIT PRICE BID FOR ITEM 638 - STANDARD HYDRANT ASSEMBLY.

ALL HYDRANTS ARE TO BE FACTORY PAINTED.

PROTECTION AND PAINTING

ALL IRON PARTS OF VALVES AND ACCESSORIES SHALL BE PAINTED BEFORE LEAVING THE SHOP WITH TWO COATS OF ACCEPTABLE HIGH GRADE BITUMINOUS PAINT. THE VALVES SHALL BE PROTECTED AT ALL TIMES FROM RUST OR DAMAGE, BOTH BEFORE AND AFTER INSTALLATION, UNTIL THE COMPLETION OF THE CONTRACT.

INSTALLATION - WATERLINE

THE PIPE SHALL BE LAID ON A PROPERLY SHAPED AND FIRM, GRANULAR BEDDING MEETING REQUIREMENTS OF ITEM 638.05 OF THE CURRENT ODOT CONSTRUCTION AND MATERIAL SPECIFICATIONS. WHERE CONDITIONS WARRANT, UNSUITABLE MATERIAL SHALL BE REMOVED AND GRANULAR MATERIAL CONFORMING TO THE SPECIFICATION SHALL BE USED FOR BEDDING.

ALL PIPE AND APPURTENANCES SHALL BE INSTALLED TRUE TO LINE, GRADE AND LOCATION, WITH JOINTS CENTERED, SPIGOTS HOME, PROPER SUPPORT AND RESTRAINT PROVIDED AND ALL VALVE STEMS PLUMB. CARE SHALL BE USED TO LAY THE PIPE SO THAT IT IS SUPPORTED BY THE FULL LENGTH OF THE BARREL. THE PIPE SHALL HAVE APPROXIMATELY 5' OF COVER. WHERE CONFLICTS OCCUR WITH OTHER UTILITIES, A MINIMUM OF 18 INCHES OF VERTICAL SEPARATION IS REQUIRED. WHERE CONDITIONS WARRANT, THE DEPTH OF COVER MAY BE CHANGED.

INSTALLATION - FIRE HYDRANT ASSEMBLY

ANCHOR COUPLINGS SHALL BE USED TO HARNESS THE HYDRANT WATCH VALVE TO THE MAINLINE TEE. THE HYDRANT SHALL BE HARNESSSED TO THE VALVE USING EITHER A NIPPLE MECHANICAL JOINT RESTRAINT OR ANCHOR COUPLINGS.

APPROXIMATELY 1/2 CUBIC YARD OF #6 STONE SHALL BE PLACED AROUND THE BARREL OF THE HYDRANT. THE STONE SHALL NOT BE PLACED CLOSER THAN 2 FEET TO THE GROUND SURFACE. STONE SHALL THEN BE COVERED WITH AN APPROVED PLASTIC TO PREVENT SOIL INFILTRATION.

HYDRANTS SHALL BE TURNED BY THE CITY OF SYLVANIA.

WHENEVER POSSIBLE, HYDRANTS SHALL BE LOCATED NO CLOSER THAN 3 FEET OR NO FURTHER THAN 8 FEET BEHIND THE CURB OR EDGE OF PAVEMENT.

THE CENTERLINE OF THE BREAKER FLANGE SHALL BE USED TO DETERMINE THE HYDRANT ELEVATION AS NOTED ON THE PLANS. THE CENTERLINE OF THE BREAKER FLANGE SHALL BE NO HIGHER THAN 6 INCHES ABOVE AND NO LOWER THAN 3 INCHES BELOW THE FINISHED GROUND GRADE.

BACKFILLING

ALL TRENCHES AND EXCAVATIONS SHALL BE BACKFILLED IMMEDIATELY AFTER PIPE IS LAID THEREIN. NO MATERIAL SHALL BE USED FOR BACKFILLING THAT CONTAINS STONES, ROCK OR PIECES OF MASONRY, FROZEN EARTH, DEBRIS OR EARTH WITH AN EXCEPTIONALLY HIGH VOID CONTENT.

TRENCHES OUTSIDE THE LIMITS OF 5 FEET FROM THE EDGE OF PAVEMENT, PAVED OR STONE BERM OR BACK OF CURB SHALL BE BACKFILLED WITH THOROUGHLY TAMPED GRANULAR MATERIAL, A MINIMUM OF 12 INCHES ABOVE THE TOP OF THE PIPE. THE REMAINDER OF THE TRENCH MAY BE FILLED WITH EXCAVATED MATERIAL, INSOFAR AS IT IS OF SUITABLE CHARACTER.

TRENCHES WITHIN 5 FEET OF THE BACK OF CURB, EDGE OF PAVEMENT OR EDGE OF PAVED OR STONE BERM SHALL BE BACKFILLED WITH THOROUGHLY TAMPED GRANULAR MATERIAL TO THE PAVEMENT SUBGRADE. GRANULAR BACKFILL SHALL CONFORM TO THE GRADATION REQUIREMENTS OF THE CURRENT SPECIFICATIONS FOR ITEM 703.11, TYPE 1, ITEM 304.

GRANULAR MATERIAL MAY BE COMPACTED WITH WATER IF SATISFACTORY DRAINAGE IS PROVIDED FOR THE FREE WATER. WHEN COMPACTING WITH WATER, THE GRANULAR MATERIAL MAY BE PLACED IN LAYERS NOT TO EXCEED 8 INCHES LOOSE DEPTH AND EACH LAYER THOROUGHLY SATURATED WITH WATER BY FLOODING OR JETTING. PRIOR TO THE PLACEMENT OF SOIL OVER THE GRANULAR MATERIAL THE EXCESS FREE WATER SHOULD BE DRAINED.

PRESSURE TESTING

THE CONTRACTOR SHALL MAKE PRESSURE AND LEAKAGE TESTS OF ALL PIPE LINES UNLESS OTHERWISE DIRECTED BY THE CITY OF SYLVANIA. PRESSURE TESTS SHALL BE MADE IN ALL PIPE LINES OR VALVED SECTIONS THEREOF AS DIRECTED BY THE CITY. BEFORE TESTING OF THE MAIN, THE CONTRACTOR SHALL FLUSH THE MAIN UNDER THE CITY OF SYLVANIA'S SUPERVISION TO EXPEL ANY WATER, DIRT, CHLORINE, ETC., IN COMPLIANCE WITH AWWA C-600.

THE CONTRACTOR SHALL PROVIDE ALL EQUIPMENT NECESSARY TO SATISFACTORILY PERFORM THE TEST, WITH THE EXCEPTION OF A PRESSURE GAUGE AND A METER TO MEASURE THE AMOUNT OF WATER USED DURING THE TEST.

HYDROSTATIC PRESSURE SHALL BE APPLIED BY MEANS OF A PUMP, TAKING WATER FROM AN AUXILIARY SUPPLY. THE BEGINNING TEST PRESSURE SHALL BE 150 PSI AND EACH TIME THE PRESSURE FALLS TO 140 PSI IT MUST BE PUMPED BACK TO 150 PSI, YIELDING AN AVERAGE TEST PRESSURE OF 145 PSI FOR A TWO HOUR PERIOD. THE FORMULA TO DETERMINE THE ALLOWABLE LEAKAGE IS AS FOLLOWS:

$$W = LD \times (\text{SQUARE ROOT OF } P) / 133,200$$

W = ALLOWABLE LEAKAGE (GAL/HOUR)
L = LENGTH OF PIPELINE BEING TESTED (FEET)
D = NOMINAL DIAMETER OF PIPE (INCHES)
P = AVERAGE TEST PRESSURE DURING TEST (PSI)

MAINTENANCE BOND

THE CONTRACTOR SHALL PROVIDE A ONE YEAR MAINTENANCE BOND IN THE AMOUNT OF 25% OF THE CONSTRUCTION COST UPON COMPLETION OF THE PROJECT. THE COST OF THIS MAINTENANCE BOND SHALL BE INCLUDED WITH THE UNIT COST OF THE PERTINENT BID ITEMS.

STERILIZATION

THE CONTRACTOR SHALL CHLORINATE ALL PIPE LINES, AND THIS SHALL BE DONE PRIOR TO PRESSURE TESTING UNLESS OTHERWISE DIRECTED BY THE CITY OF SYLVANIA. THE CHLORINATION SHALL YIELD A CONCENTRATION OF APPROXIMATELY 50 PPM AND REMAIN IN THE LINES FOR A PERIOD OF 72 HOURS AT A PRESSURE NOT TO EXCEED 50% OF THE NORMAL STATIC PRESSURE IN THE AREA. UPON TERMINATION OF THE PERIOD OF CHLORINATION THE LINES SHALL BE FLUSHED UNDER CITY SUPERVISION INTO A SANITARY SEWER UNTIL THE CHLORINE RESIDUAL IS REDUCED TO APPROXIMATELY 2 PPM. FOLLOWING COMPLETION OF A LEAKAGE TEST, APPROPRIATE BACTERIOLOGICAL SAMPLES WILL BE COLLECTED BY CITY PERSONNEL.

DISINFECTION SHALL MEET OR EXCEED AWWA C-651.

OHIO E.P.A. REQUIREMENTS

THE OHIO ENVIRONMENTAL PROTECTION AGENCY REQUIRES CONFORMANCE TO THE 2003 EDITION OF "TEN STATES STANDARDS." THIS STANDARD SHALL BE EQUALLED OR EXCEEDED FOR WATERLINES. SPECIAL ATTENTION SHALL BE GIVEN TO THE FOLLOWING SECTIONS OF PART 8.

- 8.1.1 MATERIALS CONFORM TO AWWA STANDARDS
- 8.2.2 MINIMUM 6" DIAMETER FIRE PROTECTION
- 8.4.4 HYDRANT DRAINAGE
- 8.7.3 MINIMUM 5' GROUND COVER
- 8.7.5 PRESSURE TESTING AWWA C-600*
- 8.7.6 DISINFECTION AWWA C-651*
- 8.8.2 10' HORIZONTAL SEPARATION WATER MAIN/SEWER
- 8.8.3 18" VERTICAL SEPARATION WATER MAIN/SEWER
- 8.8.6 NO ENTRY AND/OR CONTACT WITH SEWER MANHOLE

* NOTE: IT SHALL BE THE CONTRACTOR'S RESPONSIBILITY TO PERFORM THIS TEST PROPERLY AND THEIR RESPONSIBILITY FOR ADEQUATE SUPERVISION AND APPROVAL RESTS WITH THE APPROPRIATE GOVERNMENTAL AGENCY. ANY DEVIATION FROM THE ABOVE WILL NOT BE PERMITTED UNLESS SPECIFICALLY INCLUDED IN THE GENERAL NOTES OR OTHERWISE SHOWN ON THESE PLANS.

IN CASES WHERE ONE AND/OR MORE OF THE ABOVE MENTIONED OHIO E.P.A. STANDARDS FALL SHORT OF THE CITY OF SYLVANIA, THE LATTER SHALL GOVERN.

FLUSHING EXISTING WATER MAINS

WHENEVER A CONTRACTOR IS CONNECTING ONTO AN EXISTING WATER MAIN, THE EXISTING WATER MAIN WILL BE FLUSHED BY THE CITY THROUGH THE BLOW-OFF ON THE END OF THE MAIN BEFORE THE NEW PIPE IS CONNECTED TO THE EXISTING WATERLINE.

WATER TAPS AND SERVICE CROSSOVERS

SERVICE LINES THAT MUST CROSS UNDER PAVEMENT SHALL, PRIOR TO PAVEMENT INSTALLATION, BE EXTENDED TO EACH LOT USING A 1 INCH TYPE K COPPER IN SOFT ROLLS. UNLESS OTHERWISE DIRECTED BY THE CITY, NO COUPLINGS WILL BE PERMITTED IN THESE LINES. ALL SERVICES SHALL BE PLACED AT A DEPTH OF 5 FEET BELOW THE TOP OF THE CURB. THE CITY REQUIRES THE STREET TO BE ROUGH GRADED PRIOR TO INSTALLATION OF THESE SERVICES TO AID IN AVOIDING FINISH ELEVATION CONFLICTS.

THE CONTRACTOR SHALL FURNISH AND PLACE ALL COPPER LINES AND SHALL PERFORM ALL NECESSARY EXCAVATIONS FOR THE INSTALLATION OF SERVICES UNDER CITY SUPERVISION. THE CITY WILL PROVIDE THE CURB STOPS, CORP STOPS AND CURB BOXES AND WILL MAKE THE NECESSARY TAPS. THE CONTRACTOR MUST PROVIDE A REASONABLY DRY SHAFT FOR THE CITY TO OPERATE. TAPS SHALL NOT BE MADE UNDER ANY PAVEMENT AREA.

THE UNIT PRICE BID FOR EACH LONG WATER SERVICE AND SHORT WATER SERVICE SHALL INCLUDE ALL COSTS FOR THE CONTRACTOR TO PERFORM THE NECESSARY EXCAVATION FOR THE CITY TO INSTALL THE SERVICES AS WELL AS THE NECESSARY BACKFILL REQUIRED. THE UNIT PRICE BID FOR EACH SHALL ALSO INCLUDE THE REMOVAL OF THE EXISTING CURB STOPS, CORP STOPS AND CURB BOXES.

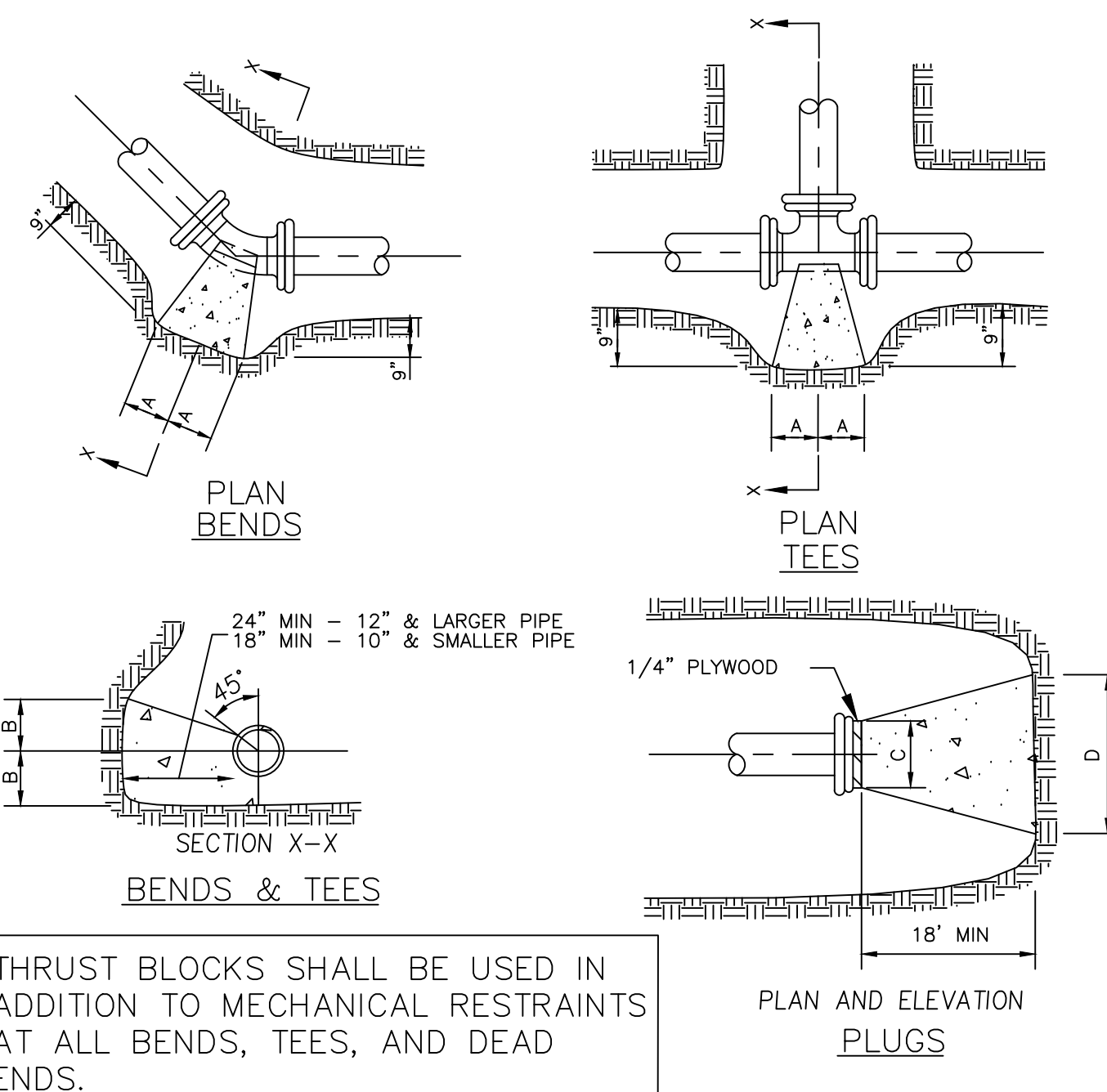

THRUST BLOCKS SHALL BE USED IN ADDITION TO MECHANICAL RESTRAINTS AT ALL BENDS, TEES, AND DEAD ENDS.

TYPE	SIZE	1/4 BENDS		1/8 BENDS		1/16 BENDS		TEES		PLUGS	
		A	B	A	B	A	B	A	B	C	D
2000 PSF SOIL	6"	16"	10"	9"	10"	6"	8"	10"	12"	10"	21"
	8"	22"	13"	12"	13"	8"	10"	13"	16"	12"	29"
	10"	26"	17"	14"	17"	10"	13"	16"	20"	14"	36"
	12"	29"	21"	16"	21"	11"	16"	18"	24"	16"	41"
	14"	35"	24"	19"	24"	12"	20"	22"	27"	18"	48"
	16"	38"	27"	21"	27"	12"	24"	24"	30"	20"	54"
	20"	46"	36"	25"	36"	15"	30"	30"	30"	24"	68"

NOTE: BASED ON 100 PSI STATIC PRESSURE PLUS AWWA WATER HAMMER ALL BEARING SURFACES TO BE CARRIED TO UNDISTURBED GROUND

THRUST BLOCKING DETAIL

N.T.S.

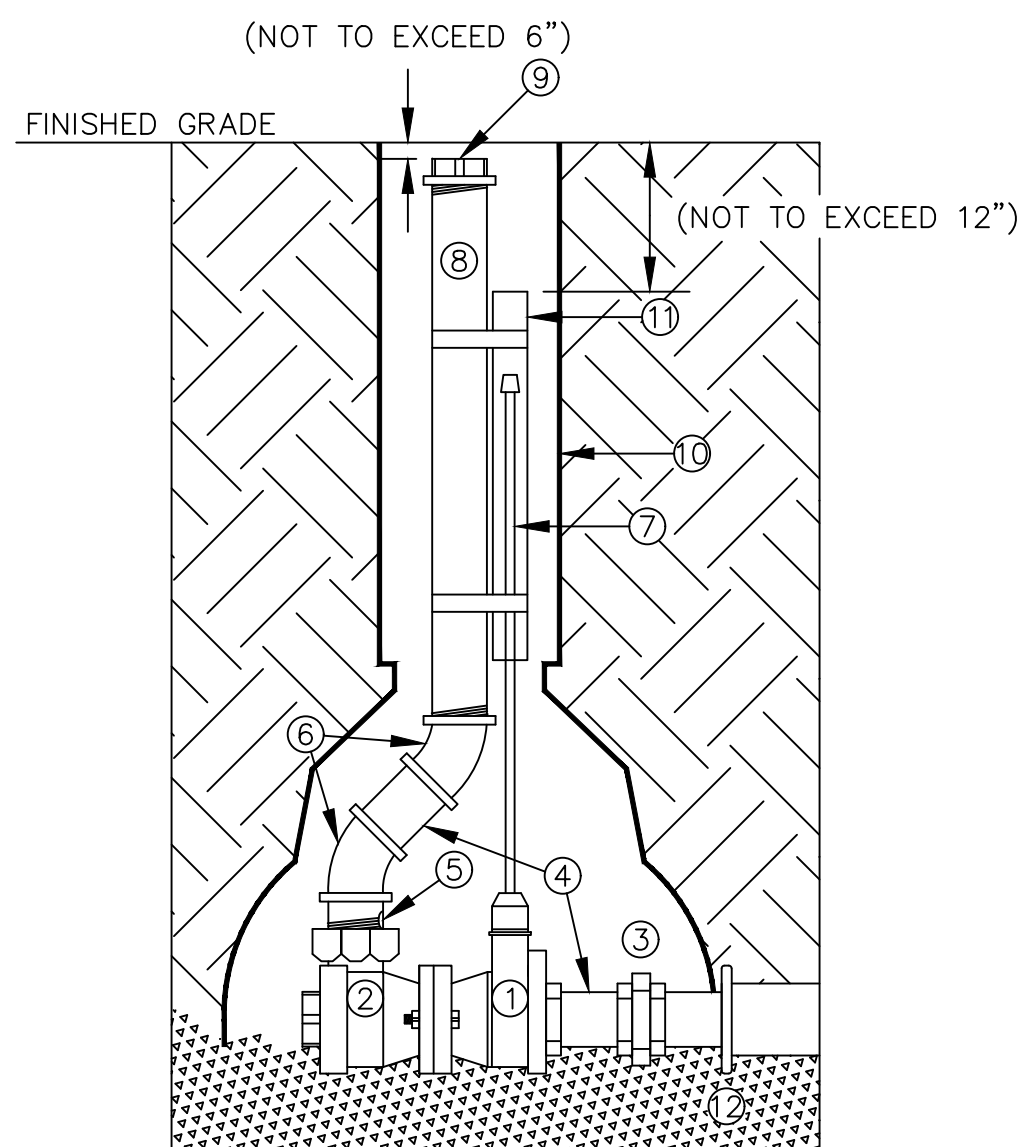

1. BF13-777 FORD BALL VALVE
2. HFA31-777 CHECK VALVE
3. 2" SCH. 80 PVC UNION
4. 2" SCH. 80 PVC PIPE (3" LONG)
5. DRAIN HOLE
6. 2" SCH. 80 PVC 45° BENDS
7. SHUT OFF ROD (ANY MNFG)
8. 2" SCH. 80 PVC PIPE
9. 2" SCH. 80 PVC CAP
10. 3-PIECE 5-1/4" CAST IRON VALVE BOX
11. 1"- SCH. 40 OR SCH. 80 PVC PIPE
12. 2" TAPPED CAP

BLOW-OFF ASSEMBLY

N.T.S.

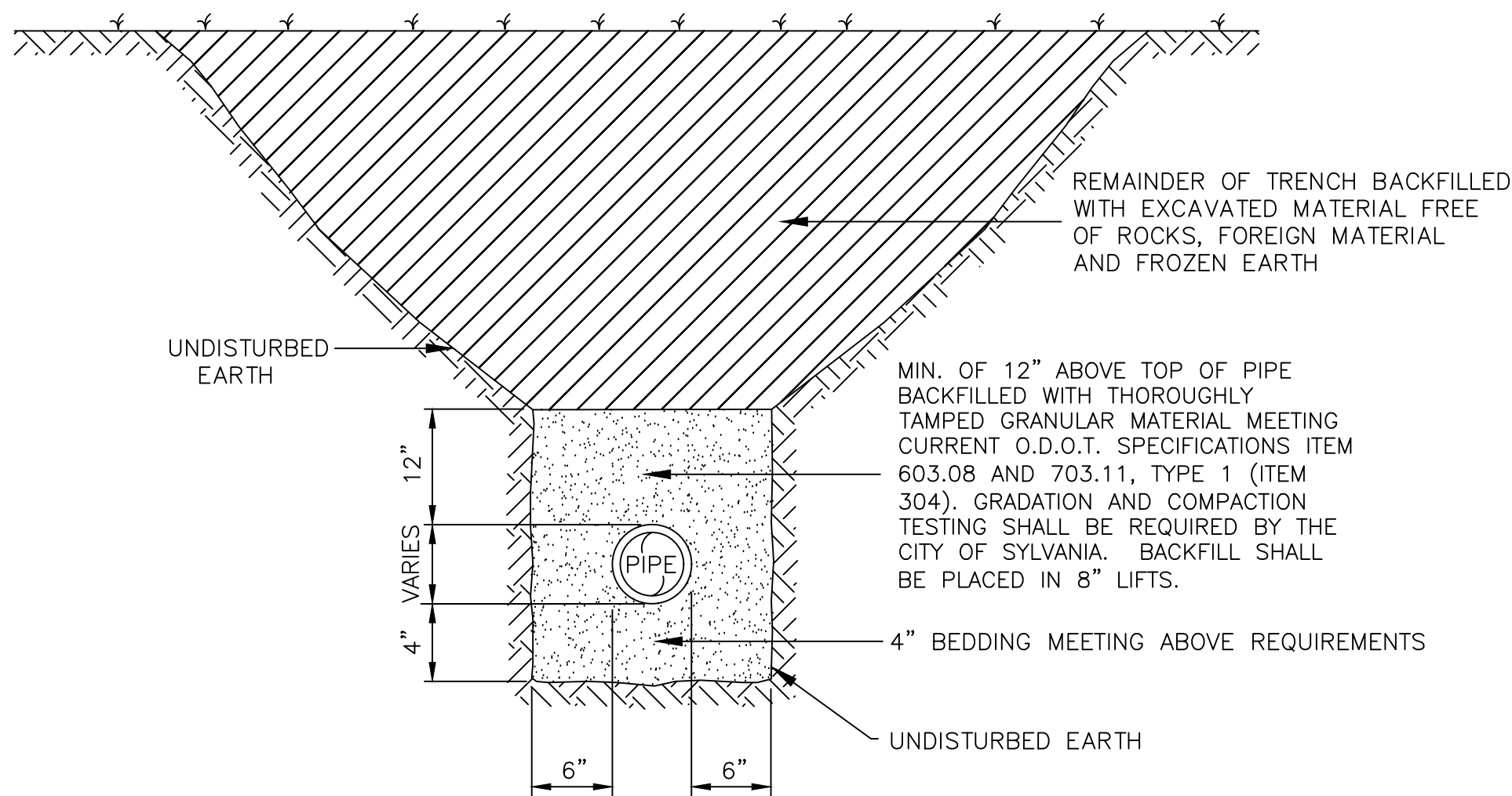

WATER MAIN BEDDING DETAIL

N.T.S.

HORIZONTAL LENGTH TO BE RESTRAINED (FEET) AT 150 PSI

Nominal Pipe Dia. (in.)	Fitting	Depth of Cover (ft.)				
		5	6	7	8	10
8	90	23(27)	19(23)	17(20)	15(17)	12(14)
8	45	10(11)	8(9)	7(8)	6(7)	5(6)
8	45 (Vertical)	20(28)	17(24)	14(21)	13(18)	10(15)
8	22.5	5(7)	4(5)	3(4)	3(3)	2(3)
8	11.25	2(3)	2(2)	2(2)	1(2)	1(1)
8	Tee or Dead End	48(69)	41(58)	35(50)	31(44)	25(36)
10	90	28(32)	24(27)	20(24)	18(21)	15(17)
10	45	12(13)	10(11)	8(10)	7(9)	6(7)
10	45 (Vertical)	12(13)	10(11)	8(10)	7(9)	6(7)
10	22.5	6(6)	5(5)	4(5)	4(4)	3(3)
10	11.25	3(3)	2(3)	2(2)	2(2)	1(2)
10	Tee or Dead End	58(83)	49(70)	43(61)	38(54)	30(43)
12	90	33(38)	28(32)	24(28)	21(25)	17(20)
12	45	14(16)	11(13)	10(12)	9(10)	7(8)
12	45 (Vertical)	28(41)	24(34)	21(30)	18(26)	15(21)
12	22.5	6(8)	5(6)	5(6)	4(5)	3(4)
12	11.25	3(4)	3(3)	2(3)	2(2)	2(2)
12	Tee or Dead End	68(98)	58(83)	50(72)	44(63)	36(51)
16	90	49	42	36	32	26
16	45	20	17	15	13	11
16	45 (Vertical)	52	45	39	34	28
16	22.5	10	8	7	6	5
16	11.25	5	4	4	3	3
16	Tee or Dead End	127	107	93	82	67

RESTRAINED LENGTHS FOR BENDS SHALL BE USED ON ALL FITTINGS ON EACH SIDE OF BEND. RESTRAINED LENGTHS FOR TEES SHALL BE ON BRANCH OF TEE. SITUATIONS NOT LISTED ON THIS TABLE (EXAMPLES: REDUCERS, TEES w/ SMALLER BRANCH, DIAMETERS & VERTICAL BENDS NOT LISTED) SHALL BE AS APPROVED BY THE CITY OF SYLVANIA.

PLEASE NOTE: POLYETHYLENE ENCASED PIPE REQUIRES ADDITIONAL RESTRAINT DUE TO A LOWER FRICTION LOSS. (FOOTAGES IN PARENTHESIS ARE FOR POLYETHYLENE ENCASED PIPE).

MECHANICAL JOINT RESTRAINT TABLE

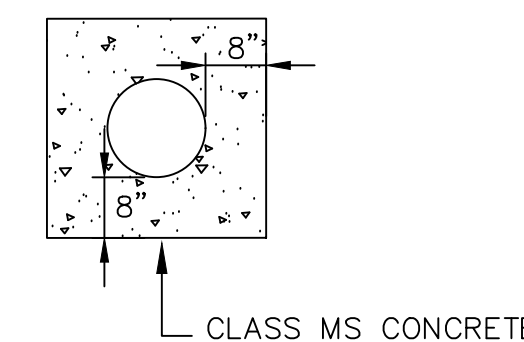

CONCRETE ENCASEMENT DETAIL

N.T.S.

(LENGTH AS SHOWN ON DETAIL SHEETS)

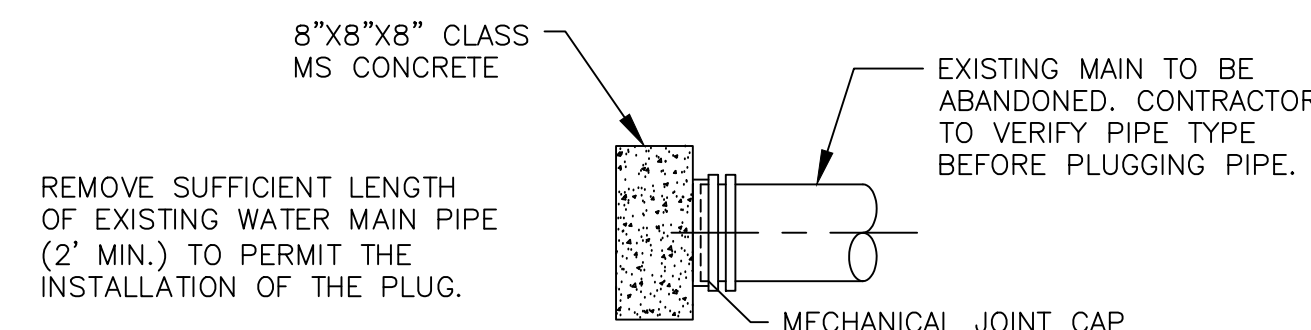

WATER MAIN PLUG DETAIL

N.T.S.

UPDATED 5/2026

DESIGNED
EMB
CHECKED
JES

WATER GENERAL NOTES

CITY OF SYLVANIA

2
3

-ALL DRIVE APPROACHES AND CROSS OVER PAVEMENT CUTS SHALL BE SAW CUT.
-DRIVE REPLACEMENT SHALL BE FROM EDGE OF PAVEMENT TO BACK OF TRENCH.
-CONSTRUCTION METHODS, EQUIPMENT AND MATERIALS PROPOSED FOR PAVEMENT RESTORATION SHALL BE APPROVED BY THE CITY OF SYLVANIA PRIOR TO BEGINNING THIS WORK.

-WHERE THE EXISTING PAVEMENT SURFACE AND/OR BASE IS DAMAGED OR UNDERMINED AS DETERMINED BY THE ENGINEER, REPLACEMENT OR RESURFACING AS DETAILED BELOW SHALL BE REQUIRED.

- ① 1 1/2" - ITEM 441 ~ ASPHALT CONCRETE, SURFACE COURSE, TYPE 1, (449), PG 64-22
- ② 2 1/2" - ITEM 441 ~ ASPHALT CONCRETE, INTERMEDIATE COURSE, TYPE 2, (449), PG 64-22
- ③ - ITEM 407 ~ TACK COAT FOR INTERMEDIATE COURSE @ 0.04 GAL./SY.
- ④ 5" - ITEM 302 ~ ASPHALT CONCRETE BASE, PG 64-22
- ⑤ 6" - ITEM 304 ~ AGGREGATE BASE
- ⑥ 12" - ITEM 304 ~ AGGREGATE BASE
- ⑦ - ITEM 408 ~ PRIME COAT @ 0.40 GAL./S.Y.

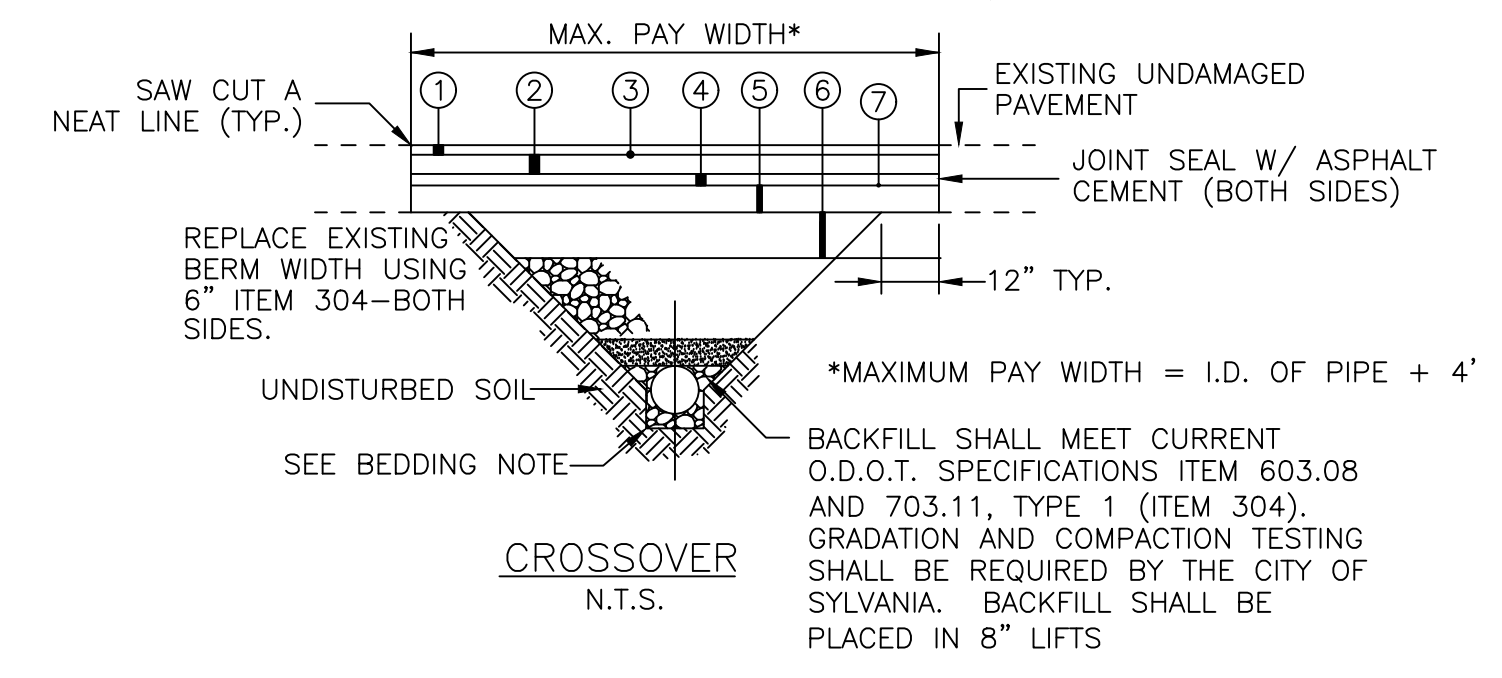

CROSSOVER
N.T.S.

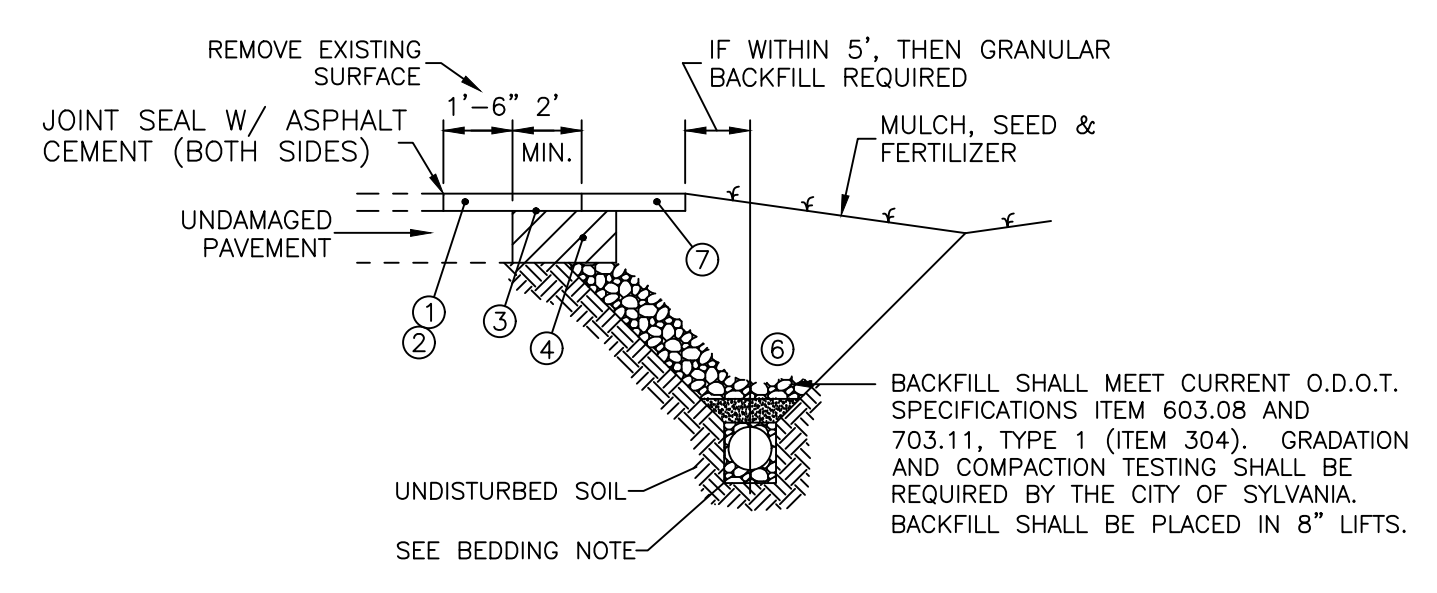

ADJACENT TO PAVEMENT

PAVEMENT REPLACEMENT DETAILS
N.T.S.

DRIVES DISTURBED DUE TO CONSTRUCTION ARE TO BE REPLACED IN KIND OR WITH THE MINIMUM THICKNESS FROM THE FOLLOWING TABLE.

- ASPHALT DRIVES
- (A) 2" - ITEM 441 ~ ASPHALT CONCRETE, SURFACE COURSE, TYPE 1, (449) PG 64-22
 - (B) - ITEM 408 ~ PRIME COAT @ 0.40 GAL./SY.
 - (C) 6" - ITEM 304 ~ AGGREGATE BASE
- CONCRETE DRIVES
- (D) 6" - ITEM 452 ~ PLAIN PORTLAND CEMENT CONCRETE
- STONE DRIVES
- (E) 6" - ITEM 304 ~ AGGREGATE BASE

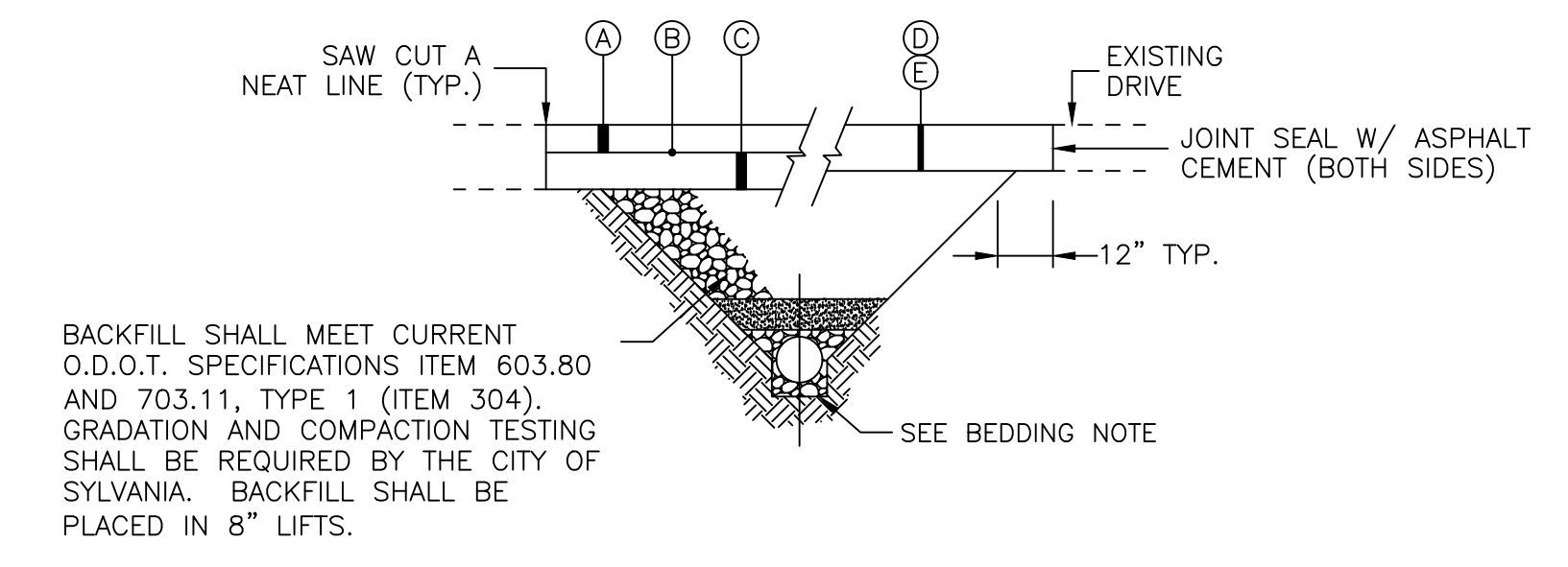

ALL DRIVE APPROACHES AND X-OVER PAVEMENT CUTS SHALL BE SAW CUT.
DRIVE REPLACEMENT SHALL BE FROM EDGE OF PAVEMENT TO BACK OF TRENCH, OR TO THE NEXT JOINT FOR CONCRETE DRIVEWAYS.

DRIVEWAY REPLACEMENT DETAILS
N.T.S.

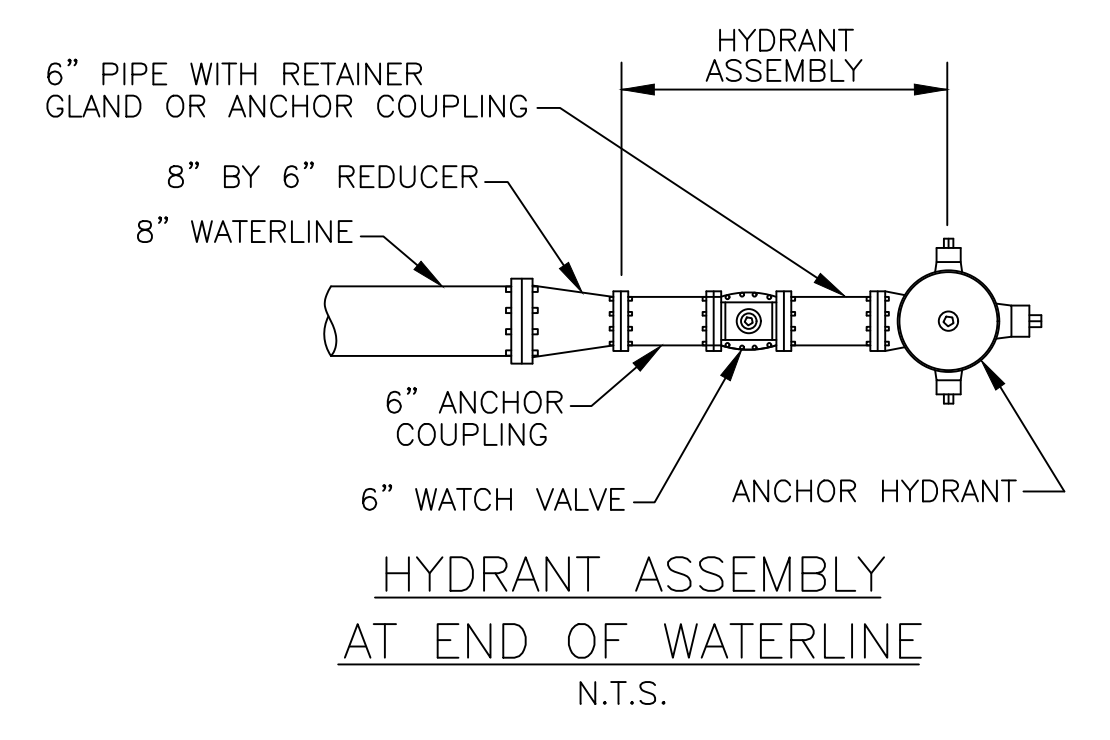

HYDRANT ASSEMBLY AT END OF WATERLINE
N.T.S.

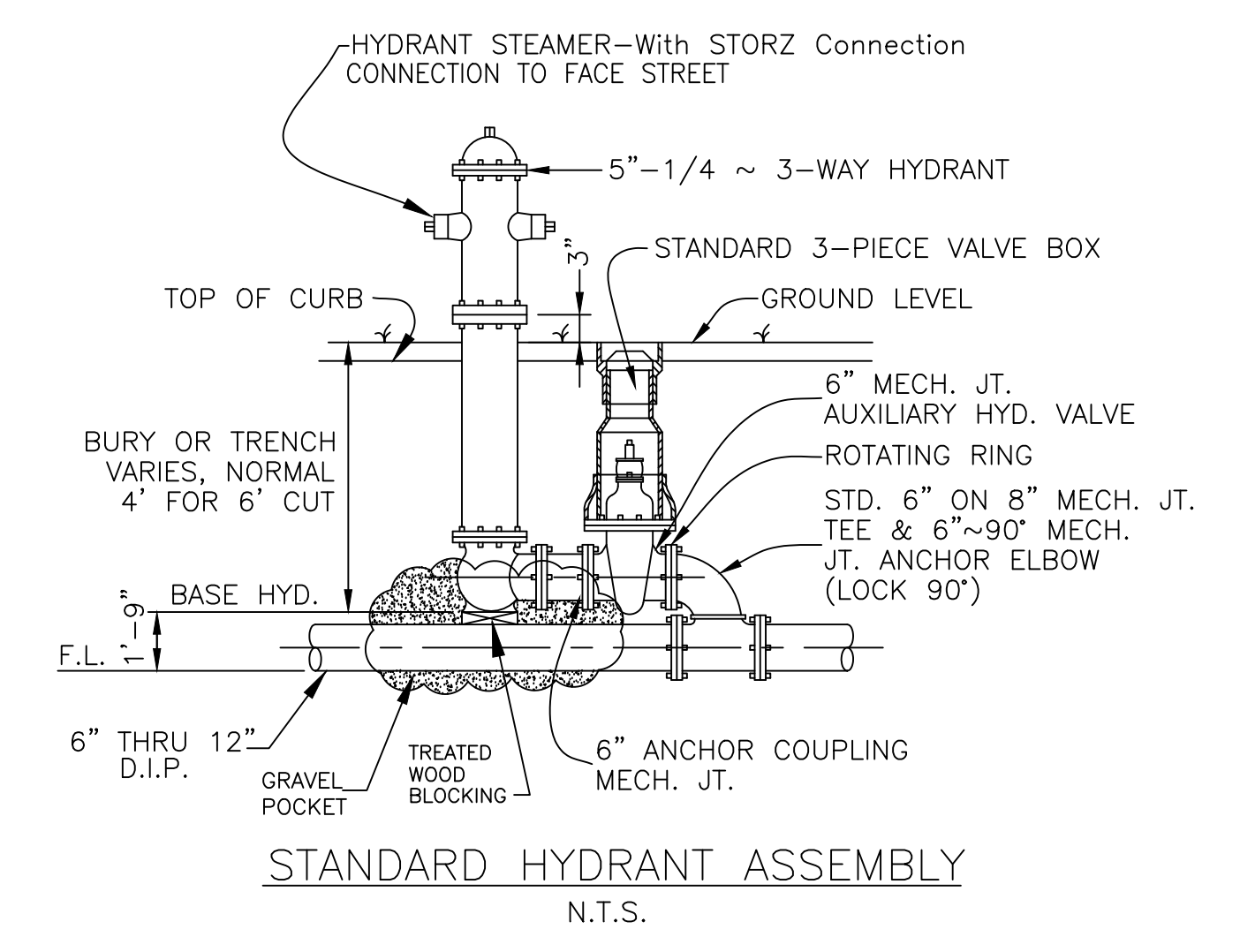

STANDARD HYDRANT ASSEMBLY
N.T.S.

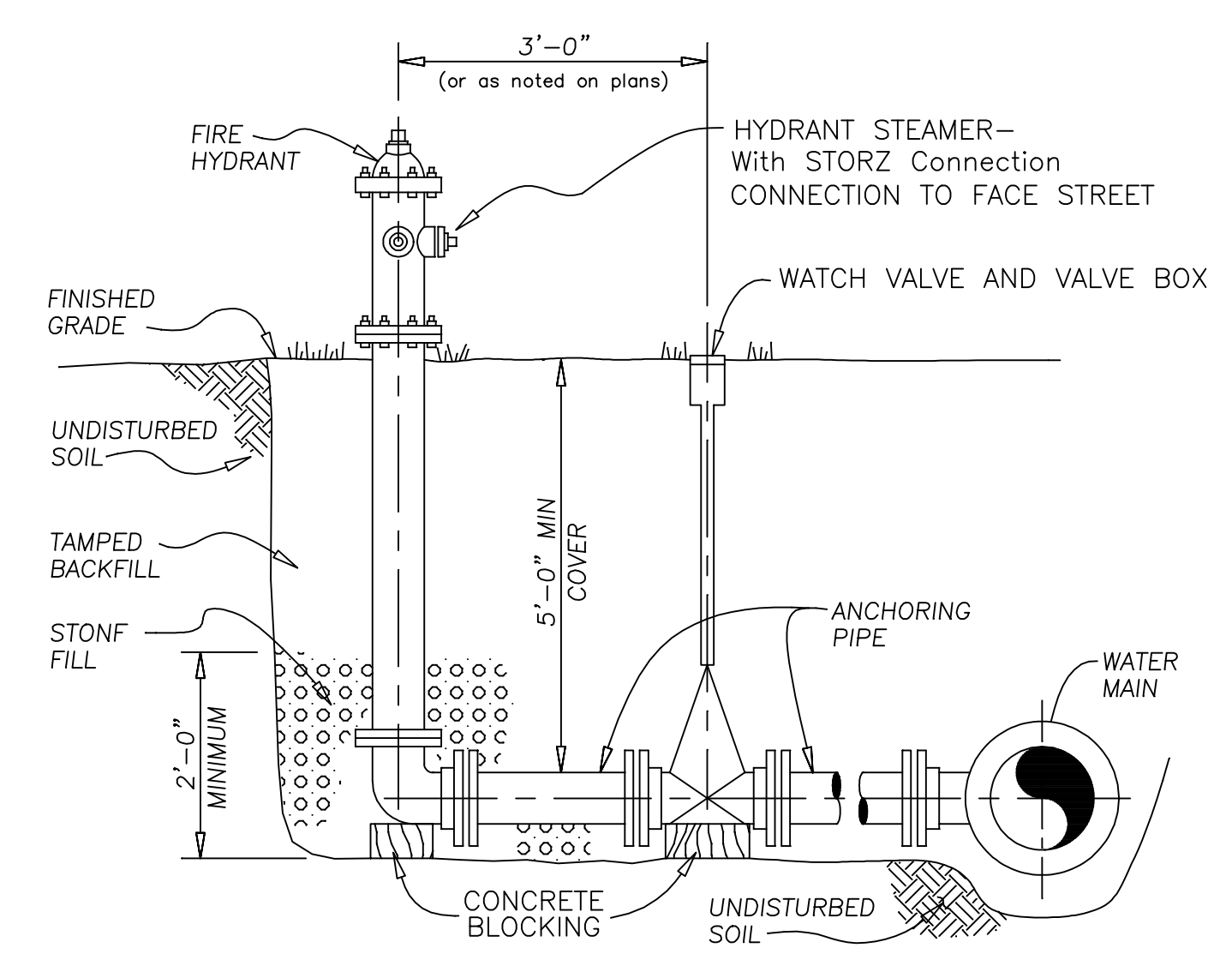

SECTION SPECIAL HYDRANT ASSEMBLY
N.T.S.

UPDATED 5/2026